

- 1
- 2
- 3
- 4
- 5
- 6
- 7
- 8
- 9
- 10
- 11
- 12
- 13
- 14
- 15
- 16
- 17
- 18

## ENDS AND SENSOR HOLDER

Polypropylene based (PP) technopolymer, black colour, matte finish.

## AXIS AND ROTOR PROPELLER

Polypropylene based (PP) technopolymer, red colour. AISI 304 stainless steel sensor activating clips.

## TUBULAR WINDOW

Borosilicate glass, high-resistance, also suitable for use with glycol-based solutions.

## SENSOR

Nickel-plated brass inductive sensor

## TIE RODS

AISI 316L stainless steel.

## PACKING RINGS

NBR synthetic rubber.

## STANDARD EXECUTION

Brass bosses with cylindrical gas thread according to UNI ISO 228/1.

## MAXIMUM CONTINUOUS WORKING TEMPERATURE

100° C.

## FEATURES AND APPLICATIONS

The indicator can be mounted in any position.

In case of mounting on rigid tubes, it is recommended to place the indicator perfectly aligned with the tubes.

The indicator operates with two-way liquid flows with a viscosity lower than 30cSt.

In order to allow the propeller rotation, a minimum flow rate is required depending on the type of fluid and its viscosity.

At the passage of the minimum flow rate, the rotor starts to rotate with a speed proportional to the fluid flow.

The inductive sensor, completely separated from the liquid passage area, reads the passage of the two metal clips mounted on the rotor, providing a frequency variation that can be transformed into a reading of the flow rate by connection to a PLC.

## ASSEMBLY INSTRUCTIONS

To ensure the correct operation of the rotor, it is necessary to wash and purge the circuit before mounting the indicator, to eliminate any particles to work in clean fluid conditions.

Since the presence of air bubbles in the fluid can give rise to measurement errors, it is advisable to mount the indicator before valves and / or other components that could create cavitation.

## SPECIAL EXECUTIONS ON REQUEST

- AISI 316 stainless steel bosses.
- Bosses with NPT conical threads.
- Axis and rotor propeller in blue colour.

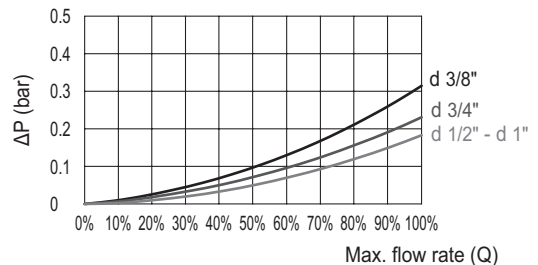

Sensor	Inductive
Power supply	10 – 30 Vcc
Input	10 mA
Max load	200 mA
Short circuit protection	Yes
Reverse polarity protection	Yes
Output	PNP
Connector	M12x1 – 4 poli
Protection class	IP67

## PNP

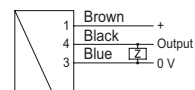

**MEASURING RANGE**

The total measuring range Q1 indicates the range between the minimum and maximum flow rate value in which the sensor provides a reading.

In the non-linear measurement range Q2 the inductive sensor provides a signal that cannot be considered accurate since the rotation of the rotor is not constant.

In the linear measuring range Q3, the pulses provide the measurement with an accuracy of ± 3%.

Both rotor wear and pressure loss increase for flow rates Q4 higher than the maximum.

The pulses per litre shown in the table represent values measured with water at 20°C and refer to average values tested with different sensors to obtain a more accurate measurement value. Compared to the value measured with water, the linear flow-frequency function can vary by ± 10% depending on the density of the liquid used or its temperature.

It is therefore recommended a specific calibration for each type of liquid used. The repeatability of the measurement is ± 3%, referred to the full scale frequency.

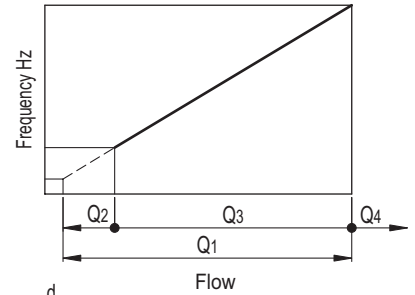
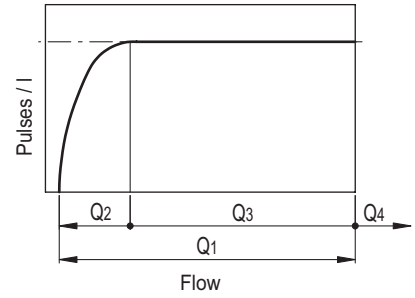

HVF-E (G3/8 - G1/2)

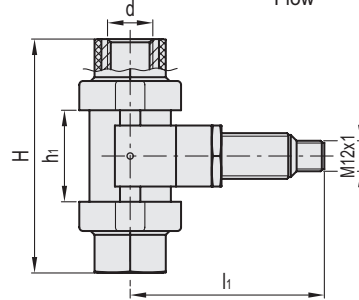
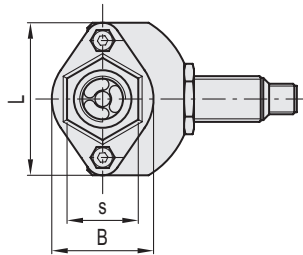

Conversion Table	
1 mm = 0.039 inch	
L	
mm	inch
60	2.36
70	2.76

**BSP**

**METRIC**

HVF-E (G3/8 - G1/2)

Code	Description	d	H	L	B	h1	s	l1	P max # Bar	Q1* l / min	Q2** l / min	Q3*** l / min	Pulses / l	Maximum Frequency Hz	△
111313	HVF.92-E-3/8	3/8	92	60	40	36	28	82	15	1.2 + 20	1.2 + 3	3 + 20	136	45	252
111315	HVF.92-E-1/2	1/2	92	60	40	36	28	82	15	1.2 + 40	1.2 + 3	3 + 40	128	86	230

HVF-E (G3/4 - G1)

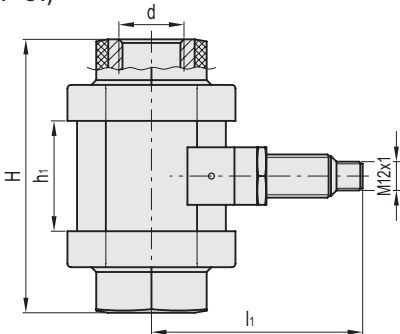
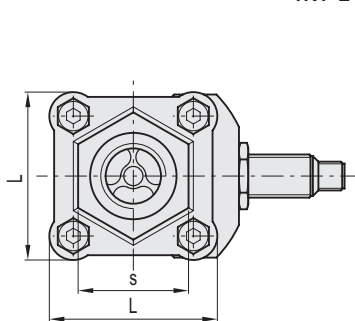

**BSP**

**METRIC**

HVF-E (G3/4 - G1)

Code	Description	d	H	L	h1	s	l1	P max # Bar	Q1* l / min	Q2** l / min	Q3*** l / min	Pulses / l	Maximum Frequency Hz	△
111335	HVF.114-E-3/4	3/4	114	70	46	46	94	12	2.1 + 60	2.1 + 5	5 + 60	30	30	747
111343	HVF.114-E-1	1	114	70	46	46	94	12	2.1 + 80	2.1 + 5	5 + 80	35	48	650

# Maximum pressure \* Total measuring range. \*\* Non linear measuring range. \*\*\* Linear measuring range.  
Flow rates Q1, Q2 and Q3 refer to the use of water at 20°.

